

TIMBER  
**SASH**  
WINDOWS





# SASH WINDOW

## SINGLE SLIDING SASH

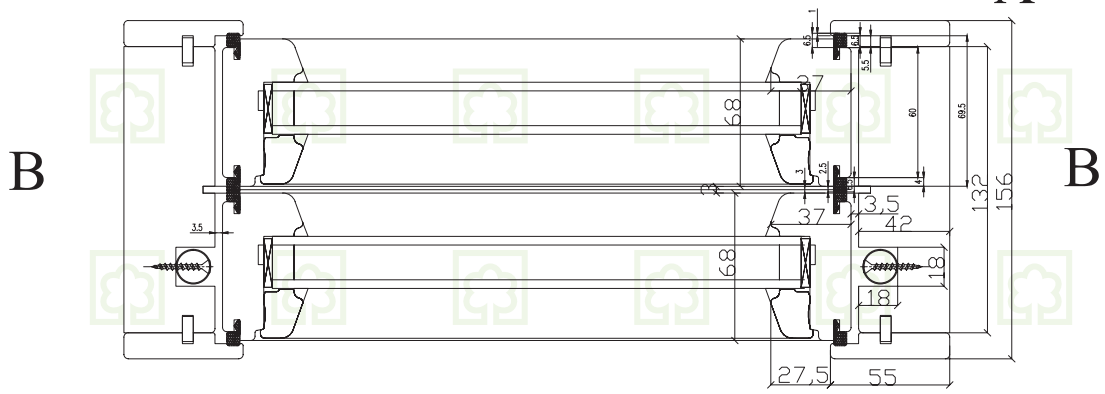
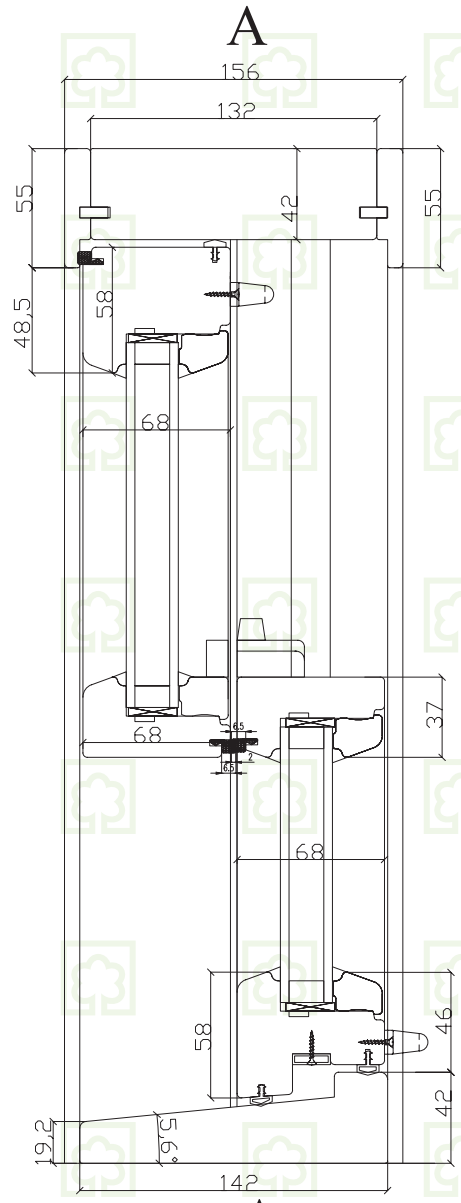
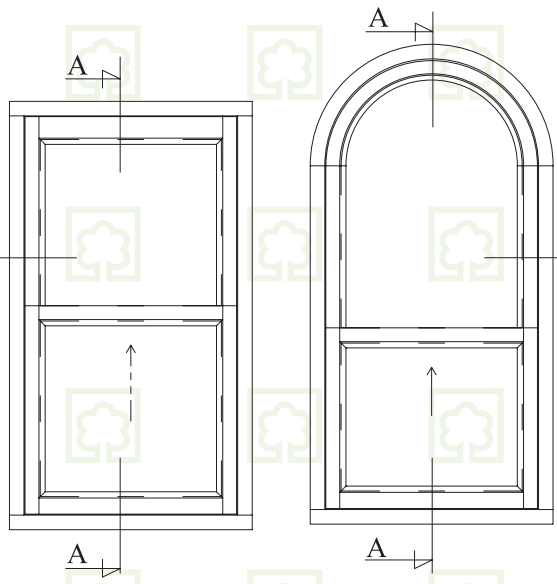

# SASH WINDOW

## TILT AND SLIDE

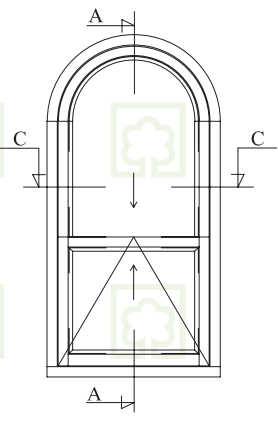
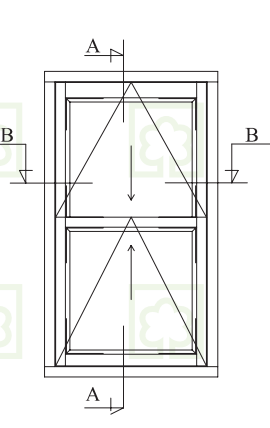

A

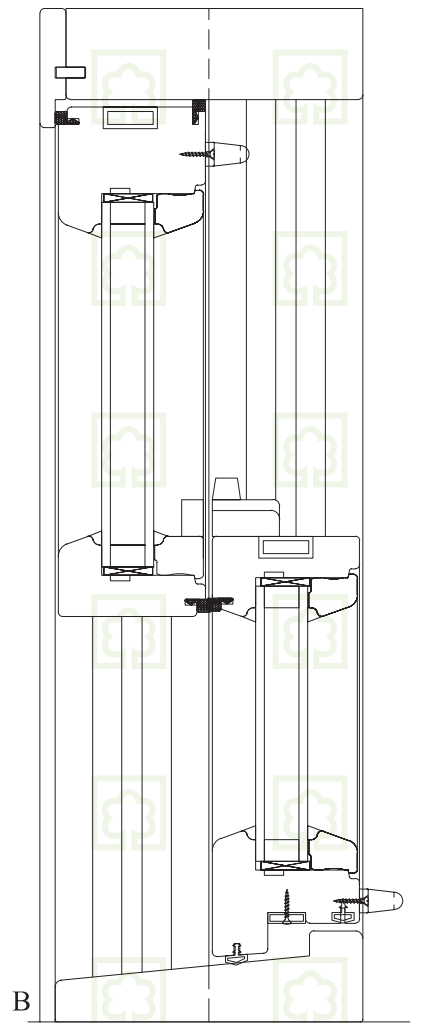
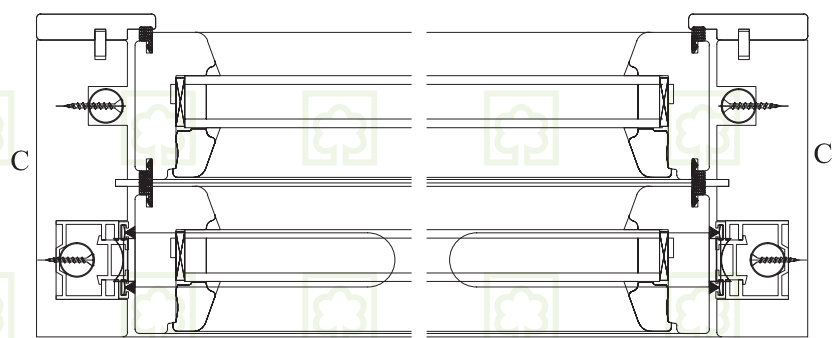
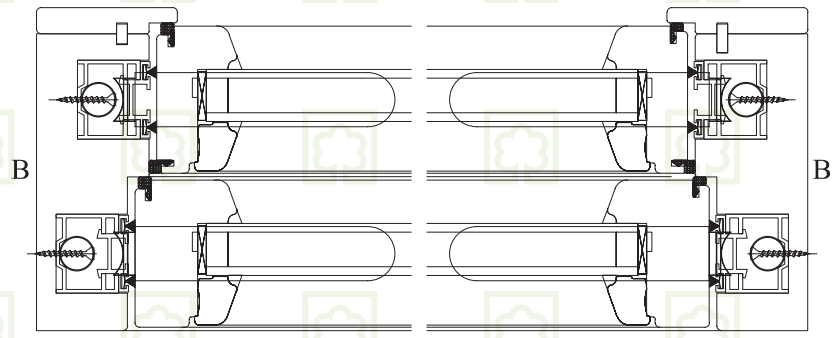

A

# SASH WINDOWS



## MATERIALS:

### Wood:

We use laminated scantlings certified FSC or PEFC of

- PINE
- OAK
- RED GRANDIS

All our wood components are treated against insects, fungi and humidity, then stained or painted according to your choice with water based products.

- Stain colours will be selected from our colour chart.
- Any RAL colour may be selected for paints.

### Balances:

High technology mechanisms combining stainless steel rod torsions and tension springs are used in keeping the balance of sashes at any point of its movement.

We also produce timber box sash windows. These are traditional vertical sliders working with weights and cords.

### Seals:

- The seals between glazing and profiles are of SILICON.
- The seals are of Q-LON (SCHLEGEL).

## IRONMONGERY:

### Bow Handles



### Cam Lock and Keeps

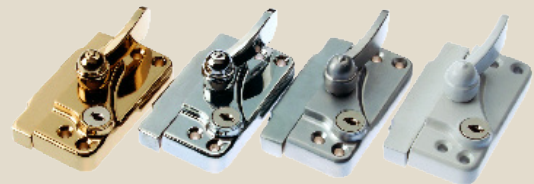

### Finger Pulls





## ELEGANT LINES

We offer the below options of profiles for use in windows to satisfy different tastes.

### EXTERIOR GLAZING BARS AND BEADS



### INTERIOR GLAZING BARS AND BEADS

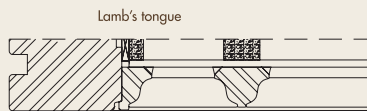
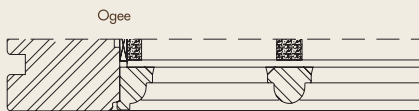
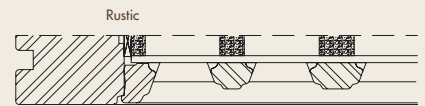
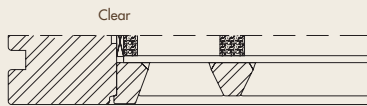
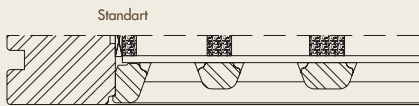

FENEX Windows Ltd  
26 St Cross Street, Clerkenwell,  
London EC1N 8UH ENGLAND  
T: +44 (0)789 9247994  
www.fenexwindows.co.uk

SELECTRON Ltd. Şti.  
Atatürk Bulvarı, Köstemir Yolu Cad. No: 74  
Silivri 34570 İstanbul / TÜRKİYE  
T: +90 212 7360801  
www.arbor.com.tr

ARBOR SAS  
16 Rue Séjourné  
94000 Créteil / FRANCE  
T: +33 (0) 1 43 77 56 36  
www.arborfenetres.fr